



RHEEM PREMIER® LOLINE SOLAR WATER HEATER

	1 - 5	270L	5 YEAR
SOLAR	PEOPLE (See Table)	CAPACITY	CYLINDER COLLECTOR (supply only) WARRANTY ⁵



MODEL NO.
596270/2SP

FEATURES

- **Complete Frost Protection** – Unique Drain-Back heat exchange technology protects in any weather extreme
- Available in a 270L capacity
- **Hard Water Tolerance** – suitable for use with most water chemistry types
- **Visual Appeal** – split systems only require slimline collectors to be mounted on the roof and feature a ground mounted tank, reducing structural load on your roof
- **Energy Efficient** – can reduce energy use by up to 50% to 70%^{1,2}
- **Booster** – choice of 6-star continuous flow gas boost or electric element back up to provide hot water in any weather condition
- Full Mains Pressure for multiple outlets simultaneously³
- Internally mounted pump and controller
- Low maintenance ground level tank
- **LED Display** – enables you to easily check the operating status of the water heater
- Top mounted solar connections
- Eligible for STCs⁴
- 5 Year Cylinder and Collector Warranty⁵



MODEL NO.
591270/2SP

FROST PROTECTION

Specifically designed for environments prone to frost, the Rheem Premier® Loline incorporates Drain-Back heat exchange technology to maximise solar gain and protect against all weather extremes. The Premier Loline replaces water in the collectors with a special heat exchange fluid with anti-freeze properties. The design is both safe and efficient, as fluid drains out of the collectors to prevent overheating in hot climates.

BOOSTER OPTIONS

The 270 litre Premier Loline offers on-site integrated gas boosting or in-tank electric boost options.

Gas boost models incorporate a 26L/min 6-star continuous flow water heater providing outstanding backup on cloudy days.

The electric model is suitable for connection to a continuous tariff and features automatic electronic controls.





RHEEM PREMIER® LOLINE SOLAR WATER HEATER

MODEL	GAS			ELECTRIC ⁶	
	596270/1SP	596270/2SP	596270/3SP	591270/2SP	591270/3SP
	596270/1CS07	596270/2CS07	596270/3CS07	591270/2CS07	591270/3CS07
Storage Capacity	L	270	270	270	270
Solar Collectors	SPA2000 or CSA2007	1	2	2	3
Booster Type		Gas – Integrated	Gas – Integrated	Gas – Integrated	Electric
Boost Capacity	L	26L/min	26L/min	26L/min	125
People Per Household		2-5	2-5	2-5	1-3
Dimensions & Specifications					
Height (A)	mm	1787	1787	1787	1775
Width (B)	mm	650	650	650	650
Depth (C)	mm	890	890	890	682
Weight Empty – Tank	kg	165	165	165	146
Weight Full – Tank	kg	435	435	435	416
Weight Empty – Solar Collectors	kg	50	100	150	100
Weight Full – Solar Collectors	kg	54	108	162	108

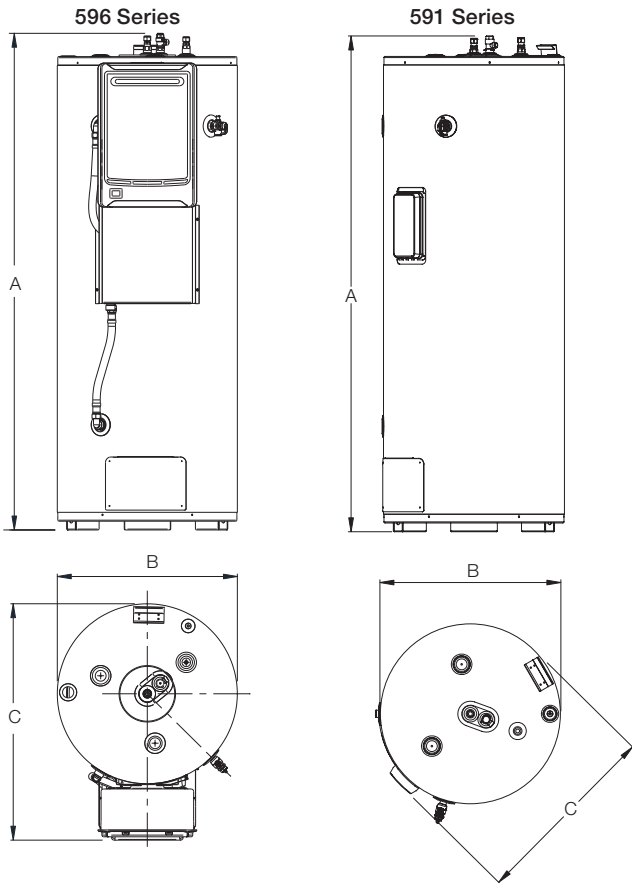

SOLAR COLLECTORS	F	G	H
CSA2007	1043	1996	82
SPA2000	1043	1996	82

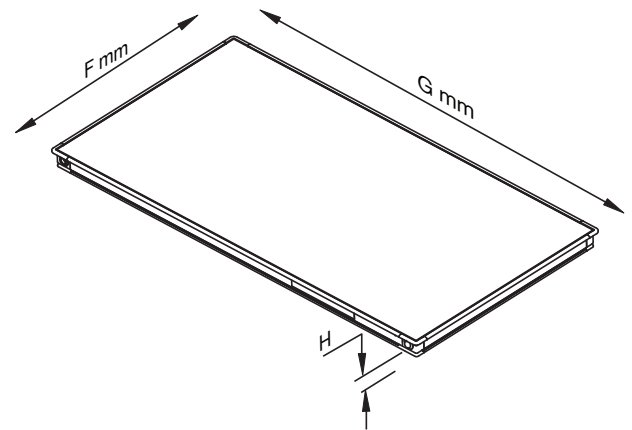

STCs

Small-scale Technology Certificates (STCs) are a financial benefit to encourage the installation of solar water heaters provided under a Federal Government legislated scheme.

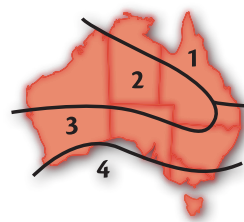

This map shows the climate Zones within Australia which will define the number of STCs allocated to an approved solar water heater. Your installation may be eligible.⁴

To claim your STC entitlement, simply complete the STC Assignment form. Visit www.rheem.com.au/rebates to download the STC Assignment form.

¹ Energy reduction of up to 50% to 65% based on Australian Government Approved TRNSYS simulation modelling of a Rheem Premier Loline 591270/2CS07 using a medium load in Zones 3 and 4 and apply when replacing an electric water heater and of up to 55% to 70% for a 596270/2SP using a medium load in zones 3 and 4 and apply when replacing a 3 star gas water heater.

² Any financial savings will vary depending upon type of Rheem Solar system installed, orientation and inclination of the solar collectors, type of water heater being replaced, hot water consumption and fuel tariff. Maximum financial savings off your hot water bill are achievable when replacing an electric water heater on continuous tariff.

³ Electric boost models only.

⁴ Eligibility criteria apply.

⁵ Warranty Conditions. Solar tank/collectors – 5 years supply on cylinder and solar collectors, 3 years labour on cylinder, 1 year labour on collector, 1 year supply and labour on other parts. Continuous flow gas booster – 10 years supply on heat exchanger, 3 years labour on heat exchanger, 3 years supply and labour on other parts. Applies to a single-family domestic dwelling only. Conditions apply, see Rheem's warranty set out in the product's Owner's Guide or view it at www.rheem.com.au/warranty. Phone 131 031 for details.

⁶ 591270 is recommended to be used with CSA2007 solar collectors in Tasmania, Victoria and South Australia. Materials and specifications correct as of 1st April 2019. Rheem Australia reserves the right to change product specifications without any prior notification.

[®] Registered Trademark of Rheem Australia Pty Ltd.

[™] Trademark of SAI Global.



Rheem Australia Pty Ltd.

1 Alan Street, Rydalmere, New South Wales 2116, Australia
PO Box 7508, Silverwater, New South Wales 2128, Australia

